

Walraven RapidRail® Beam Clamp (M8)

(G4006)

fixing to steel beam

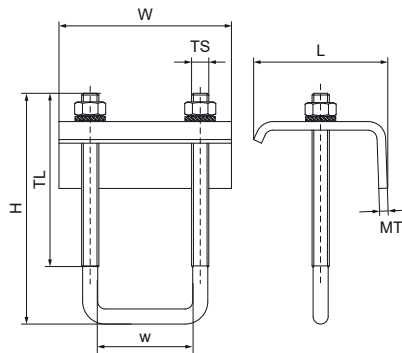

Features & benefits

- for a solid fixing to steel construction without the need for welding or drilling
- always use 2 beam clamps per fixing
- material: steel
- zinc plated
- Note! Safe load is only per set of beamclamps, per loading situation the max. allowed load of the rail must be calculated.



Product Number	For Rail Type	Clamping Range	Total Height	Total Width	Total Length	Thread Size	Thread Length	Width	Material Thickness	Maximum Allowed Load Faz	Torque Moment For Installation
Reference Letter		CR	H	W	L	TS	TL	w	MT	F _{a,z}	T _{inst.}
Unit description		mm	mm	mm	mm		mm	mm	mm	N	Nm
6585014	38x40	1 - 20	108	80	62	M8	80	44	4.00	2,500	15