

## Walraven WT7 Throughbolt Anchor

(L0346)

high performance expansion anchor for non-cracked concrete

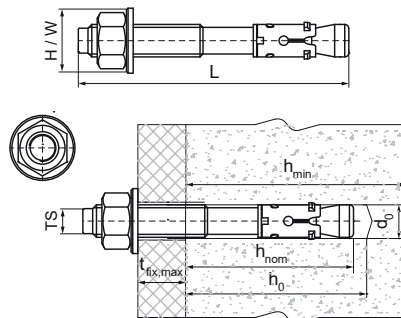

### Features & benefits

- high-performance load-capacity
- ETA Option 7 approval for non-cracked concrete
- fire resistance class R30-R120 for design of anchorages under exposure to fire
- two embedment depths provide installation flexibility
- pre- and through-fixing
- substrate type: non-cracked concrete, stone
- material: steel
- zinc plated
- for loads and more information, refer to the product data sheet and/or the ETA report



Product Number	Thread Size	Total Length	Drill Hole Diameter	Drill Hole Depth	Minimum Substrate Thickness	Maximum Fixture Thickness	Standard Embedment Depth	Recommended Load In Uncracked Concrete C20/25	Total Height	Total Width
Reference Letter	TS	L	d0	h0	hmin	tfix,max	hnom		H	W
Unit description		mm	mm	mm	mm	mm	mm	N	mm	mm
608108075	M8	75	8	65	100	5	60	6,600	16	16
608108100	M8	100	8	65	100	30	60	6,600	16	16
608110100	M10	100	10	75	110	20	67	9,000	20	20
608110120	M10	120	10	75	110	40	67	9,000	20	20
608110140	M10	140	10	75	110	60	67	9,000	20	20
608112100	M12	100	12	85	130	8	77	12,200	24	24
608112120	M12	120	12	85	130	28	77	12,200	24	24