

## Walraven W-HLX-H Concrete Screw

(L0349)

superior performance concrete screws for anchoring in cracked and non-cracked concrete

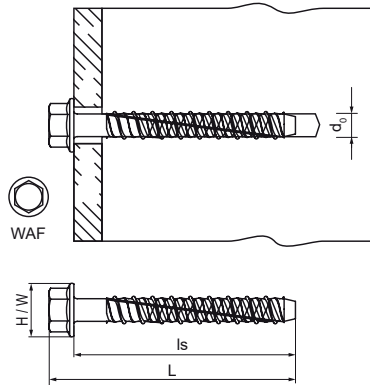

### Features & benefits

- induction hardened technology ensures very high load capacity
- up to 3 anchoring depths per size for maximum design and installation flexibility
- the advanced thread geometry ensures fast and simple installation
- reduced minimum edge and anchor spacing distances for confined areas
- installation possible without drill hole cleaning for faster workflow on site
- European Technical Assessment according to EAD 330232-01-0601 (December 2019) for mechanical fastener for use in cracked and non-cracked concrete
- European Technical Assessment according to EAD 330747-00-0601 (May 2018) for fastener for use in concrete for redundant non-structural systems
- material: steel
- zinc flake coating
- fire resistance class R30-R120
- seismic performance categories C1 and C2
- complies with VdS CEA 4001: 2024-01 (08) for applications with sprinkler systems in concrete elements
- substrate type: cracked concrete, non-cracked concrete, precast pre-stressed hollow core slabs
- for loads and more information, refer to the product data sheets and/or the ETA reports



Product Number	Screw Length	Anchor Size	Width Across Flats	Drill Hole Diameter	ETA Seismic Rating	Total Height	Total Width	Total Length
Reference Letter	ls		WAF	d0		H	W	L
Unit description	mm		mm	mm		mm	mm	mm
62510304	40	6	10	6	C1	13	13	47
62510306	60	6	10	6	C1	13	13	67
62510406	60	8	13	8	C1	16	16	68
62510408	75	8	13	8	C1 & C2	16	16	83
62510410	100	8	13	8	C1 & C2	16	16	108
62510507	70	10	15	10	C1	20	20	79
62510509	90	10	15	10	C1 & C2	20	20	99
62510510	100	10	15	10	C1 & C2	20	20	109
62510611	110	12	17	12	C1 & C2	24	24	122