

Walraven W-LX-H Concrete Screw

(L0355)

ultimate performance zinc-plated concrete screws for anchoring in cracked and non-cracked concrete

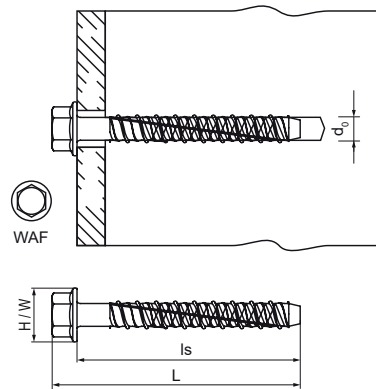

Features & benefits

- very high load capacity
- up to 3 anchoring depths provide maximum installation and design flexibility
- reduced edge and anchor spacing distances
- unique tip and thread geometry prevents concrete spalling
- material: steel
- zinc plated
- fire resistance class R30-R120
- seismic performance categories C1 and C2 (Ø 8/10/14)
- complies with VdS CEA 4001:2014-04 (05) and VdS CEA 4001:2018-01 (06) for applications with sprinkler systems in concrete elements
- substrate type: cracked concrete, non-cracked concrete, precast pre-stressed hollow core slabs
- for loads and more information, refer to the product data sheets and/or the ETA reports



Product Number	Screw Length	Anchor Size	Width Across Flats	Drill Hole Diameter	Total Height	Total Width	Total Length
Reference Letter	l_s		WAF	d_0	H	W	L
Unit description	mm		mm	mm	mm	mm	mm
62430304	40	6	10	6	14	14	47
62430306	60	6	10	6	14	14	67
62430308	75	6	10	6	14	14	82
62430406	60	8	13	8	18	18	68
62430408	75	8	13	8	18	18	83
62430409	90	8	13	8	18	18	98
62430410	100	8	13	8	18	18	108
62430412	120	8	13	8	18	18	128
62430507	65	10	15	10	22	22	74
62430509	90	10	15	10	22	22	99
62430510	100	10	15	10	22	22	109
62430512	120	10	15	10	22	22	129
62430608	75	12	16	12	27	27	87
62430610	100	12	16	12	27	27	112
62430713	135	14	19	14	32	32	148