

## Walraven Maxx HF Hammerfix

(H20526)

for fixing to Maxx Heavy Rail Profiles

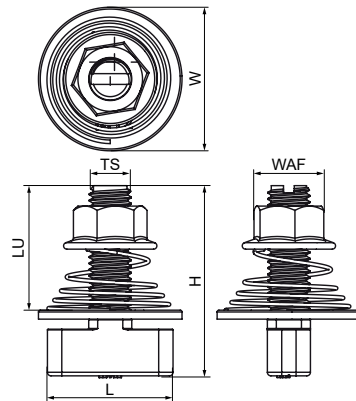

### Features & benefits

- form-locking connector
- retains assembly in place before final tightening
- pre-assembled and ready to use for a quick fixing in profile perforation by a push and 90° turn
- with visible mark on top to see the position of hammer end
- with square shaft to block in the profile hole pattern when tightening
- material: steel, strength class 8.8; spring made of stainless steel (AISI 316)
- hot dip galvanized

Product Number	For Rail Type	Thread Size	Usable Length	Total Height	Total Width	Total Length	Connection Nut Spanner Width (WAF)	Torque Moment For Installation	Maximum Allowed Load Faz
<i>Reference letter</i>		<i>TS</i>	<i>LU</i>	<i>H</i>	<i>W</i>	<i>L</i>	<i>WAFcn</i>	<i>T inst.</i>	<i>Fa,z</i>
<i>Unit description</i>			<i>mm</i>	<i>mm</i>	<i>mm</i>	<i>mm</i>	<i>mm</i>	<i>Nm</i>	<i>N</i>
65219214	80x80, 100x100, 100x120, 100x150	M12	35	55	40	40	19	75	14,500