

Walraven WT1 Throughbolt Anchor

(L0341)

ultimate performance expansion anchor for cracked concrete

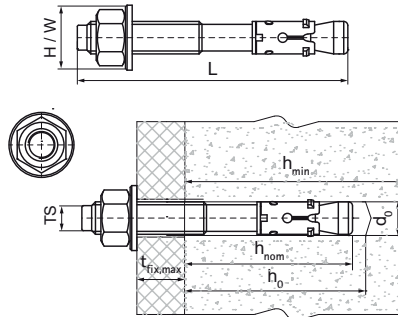

Features & benefits

- superior load capacity
- ETA Option 1 approval for cracked and non-cracked concrete
- fire resistance class R30-R120 for design of anchorages under exposure to fire
- seismic performance category C1 and C2 for design of anchorages under seismic action
- complies with VdS CEA 4001: 2024-01 (08) for applications with sprinkler systems in concrete elements
- substrate type: cracked concrete, non-cracked concrete, stone
- pre- and through-fixing
- material: steel
- zinc plated
- for loads and more information, refer to the product data sheet and/or the ETA reports

Product Number	NRF Number	Thread Size	Total Length	Drill Hole Diameter	Drill Hole Depth	Minimum Substrate Thickness	Maximum Fixture Thickness	Standard Embedment Depth	ETA Seismic Rating	Recommended Load In Cracked Concrete C20/25	Recommended Load In Uncracked Concrete C20/25	Total Height	Total Width
Reference Letter		TS	L	d0	h0	hmin	tfix,max	hnom				H	W
Unit description			mm	mm	mm	mm	mm	mm		N	N	mm	mm
608408080	1575249	M8	80	8	60	80	14	55	C1	2,700	3,900	16	16
608408095	1575250	M8	95	8	60	80	29	55	C1	2,700	3,900	16	16
608408115	1575251	M8	115	8	60	80	49	55	C1	2,700	3,900	16	16
608410090	1575252	M10	90	10	75	90	10	68	C1 & C2	5,200	8,500	20	20
608410115	1575253	M10	115	10	75	90	35	68	C1 & C2	5,200	8,500	20	20
608410135	1575254	M10	135	10	75	90	55	68	C1 & C2	5,200	8,500	20	20
608412110	1575255	M12	110	12	80	105	14	80	C1 & C2	7,100	13,300	24	24
608412120	1575256	M12	120	12	85	105	24	80	C1 & C2	7,100	13,300	24	24
608412150	1575257	M12	150	12	85	105	54	80	C1 & C2	7,100	13,300	24	24
608416145	1575258	M16	145	16	105	130	28	97	C1	12,900	16,100	30	30