

## Walraven WTB1 Throughbolt Anchor SSSt

(M9522)

high performance stainless steel expansion anchor for cracked concrete

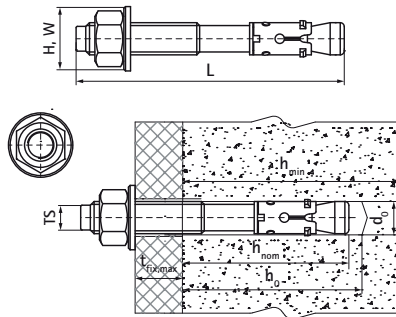

### Features & benefits

- high load capacity
- pre- and through-fixing
- made of stainless steel for use in external atmospheric environment
- two embedment depths provide installation flexibility
- material: stainless steel A4
- ETA Option 1 approval for cracked and non-cracked concrete
- fire resistance class R30-R120 for design of anchorages under exposure to fire
- substrate type: cracked concrete, non-cracked concrete, stone
- for loads and more information, refer to the product data sheet and/or the ETA report



| Product Number   | Thread Size | Total Length | Drill Hole Diameter | Drill Hole Depth | Minimum Substrate Thickness | Maximum Fixture Thickness | Standard Embedment Depth | Recommended Load In Cracked Concrete C20/25 | Recommended Load In Uncracked Concrete C20/25 | Total Height | Total Width |
|------------------|-------------|--------------|---------------------|------------------|-----------------------------|---------------------------|--------------------------|---|---|--------------|-------------|
| Reference letter | TS          | L            | d0                  | h0               | hmin                        | tfix,max                  | hnom                     |   |   | H            | W           |
| Unit description |             | mm           | mm                  | mm               | mm                          | mm                        | mm                       | N   | N   | mm           | mm          |
| 609871080        | M8          | 75           | 8                   | 55               | 100                         | 10                        | 55                       | 2,380                                       | 3,570   | 13           | 13          |
| 609871081        | M8          | 115          | 8                   | 55               | 100                         | 50                        | 55                       | 2,380                                       | 3,570   | 13           | 13          |
| 609871100        | M10         | 95           | 10                  | 69               | 100                         | 15                        | 69                       | 4,290                                       | 7,620   | 17           | 17          |
| 609871101        | M10         | 130          | 10                  | 69               | 100                         | 50                        | 69                       | 4,290                                       | 7,620   | 17           | 17          |
| 609871120        | M12         | 125          | 12                  | 80               | 140                         | 30                        | 80                       | 5,710                                       | 11,900  | 19           | 19          |
| 609871121        | M12         | 150          | 12                  | 80               | 140                         | 55                        | 80                       | 5,710                                       | 11,900  | 19           | 19          |