

Walraven Duplo Double Clamp with Lining

(A1505)

for heating pipes

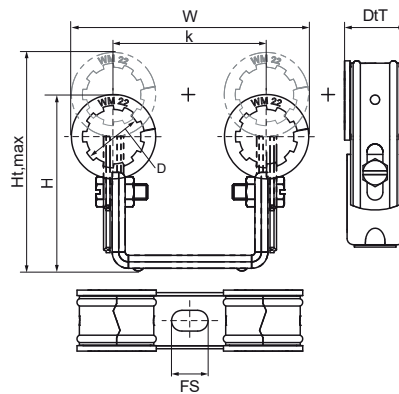

Features & benefits

- two clamps on connection bracket
- for fixing of two pipes
- space saving
- clamp shells are reinforced
- two parts of the clamp interlock
- bracket reinforced for extra strength
- tube insulation can easily be fitted
- adjustable distance between pipe and wall
- material: steel
- pre-galvanized
- sound insulating lining according DIN 4109

EPD

Product Number	Total Height	Total Width	Total Depth	Maximum Height	Fixing Slot	Heart To Heart Distance	Max. Wall Distance Center Clamp	Min. Wall Distance Center Clamp	Maximum Allowed Load Faz	Maximum Allowed Load Fax
Reference letter	H	W	DtT	Ht,max	FS	k			Fo,z	Fo,x
Unit description	mm	mm	mm	mm	mm	mm	mm	mm	N	N
3215015	65	87	25	78.75	15x8,5	60	65.25	51	200	100
3215021	69	92	25	84.25	15x8,5	59	68	53	200	100
3215027	73	100	25	88.75	15x8,5	60	69	53	200	100
3215033	81	106	25	94.75	15x8,5	60	72	58	200	100