

Walraven RapidStrut® channel DS 5 (BUP1000)

(H0405)

for medium weight fixing applications

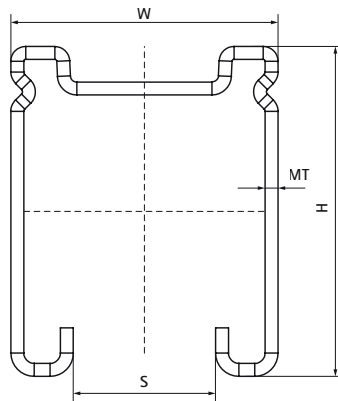
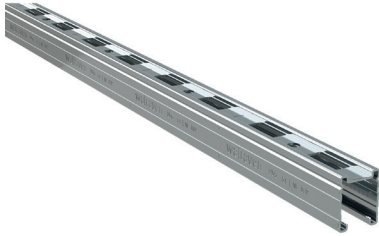

Features & benefits

- for a quick and easy fixing
- unique hole pattern, allowing Walraven RapidStrut® Accessories to be mounted on both sides of the channel
- very high corrosion resistance (Walraven UltraProtect® 1000)
- corrosion protection remains intact after cutting
- strength minimal equal to Walraven RapidStrut® 41x41x2.5 mm
- with continuous perforation
- distance between channel end and first hole is always equal
- a continuous graduated centimetre scale on one side
- inward formed flanges with serrated profile for extra grip
- material: steel 1.0242
- product is part of the Walraven UltraProtect® 1000 system
- suitable for in- and outdoor applications
- stands min. 1,000 hours salt spray test (max. 5% red rust) according to ISO 9227
- for more information about the max. allowed load (Faz) please refer to the loading tables or our online datasheet 'Walraven RapidStrut® Data Sheet'



Product Number	RSK Number	Type	Total Height	Total Width	Total Length	Material Thickness	Profile Opening
<i>Reference letter</i>			<i>H</i>	<i>W</i>	<i>L</i>	<i>MT</i>	<i>S</i>
<i>Unit description</i>			<i>mm</i>	<i>mm</i>	<i>mm</i>	<i>mm</i>	<i>mm</i>
65058252	3821575	51 M	51	41	2,000	2.00	22
65058352	3821414	51 M	51	41	3,000	2.00	22
65058652	3821400	51 M	51	41	6,000	2.00	22