

Walraven RapidStrut® Cross Connector G2 (BUP1000)

(H28134)

to make Strut rail fabrications

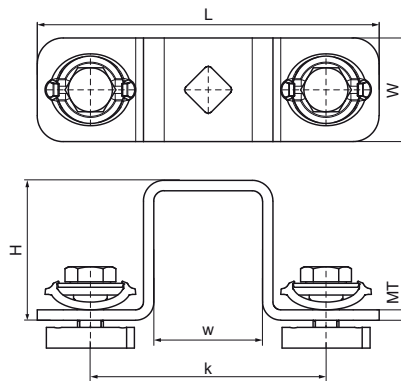

Features & benefits

- connector with pre-assembled Walraven RapidStrut® Slide nut(s)
- to make fabrication with Walraven RapidStrut® Rail
- ready-to-use pre-assembled for a quick fixing, and retains assembly in place before final tightening
- 'Direct Twist' technology for easy and secure installation
- visual guide to check the position of the slide nut
- optimized for easy installation with electrical tools
- material: metal parts made of steel 1.0332; spring(s) made of POM (polyoxymethylene), green
- product is part of the Walraven UltraProtect® 1000 system
- suitable for in- and outdoor applications
- stands min. 1,000 hours salt spray test (max. 5% red rust) according to ISO 9227



Product Number	RSK Number	For Rail Type	Total Height	Total Width	Total Length	Material Thickness	Width	Torque Moment For Installation	Maximum Allowed Load Faz	Maximum Allowed Load Fax
<i>Reference letter</i>			<i>H</i>	<i>W</i>	<i>L</i>	<i>MT</i>	<i>w</i>	<i>T_{inst.}</i>	<i>F_{a,z}</i>	<i>F_{a,x}</i>
<i>Unit description</i>			<i>mm</i>	<i>mm</i>	<i>mm</i>	<i>mm</i>	<i>mm</i>	<i>Nm</i>	<i>N</i>	<i>N</i>
665885402	3821822	41x21	34.75	40	132	4.00	40	40	8,420	4,380
665885404	4125719	41x41	54.75	40	132	4.00	40	40	8,420	4,380
665885405	3821825	41x51	64.75	40	132	4.00	40	40	8,420	4,380
665885406	3821826	41x62	74.75	40	132	4.00	40	40	8,420	4,380
665885408	3821827	41x82	94.75	40	132	4.00	40	40	8,420	4,380