

## Walraven W-HLX-PX Concrete Screw

(L0351)

zinc flake coated concrete screw with a  $\varnothing 17.0$  mm large pan head and torx T30 drive

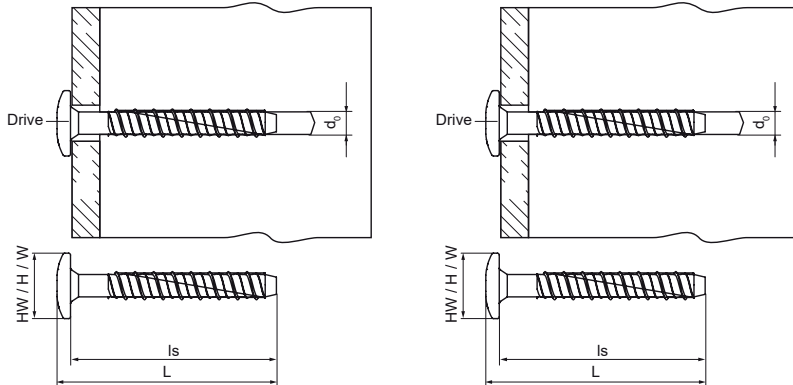

### Features & benefits

- induction hardened technology ensures very high load capacity
- the advanced thread geometry ensures fast and simple installation
- reduced minimum edge and anchor spacing distances for confined areas
- installation possible without drill hole cleaning for faster workflow on site
- suits installation with Walraven RapidStrut® Channel
- European Technical Assessment according to EAD 330232-01-0601 (December 2019) for mechanical fastener for use in cracked and non-cracked concrete
- European Technical Assessment according to EAD 330747-00-0601 (May 2018) for fastener for use in concrete for redundant non-structural systems
- material: steel
- zinc flake coating
- fire resistance class R30-R120
- seismic performance category C1
- complies with VdS CEA 4001: 2024-01 (08) for applications with sprinkler systems in concrete elements
- substrate type: cracked concrete, non-cracked concrete, precast pre-stressed hollow core slabs
- for loads and more information, refer to the product data sheets and/or the ETA reports

Product Number	RSK Number	Screw Length	Anchor Size	Key Driver Size	Drill Hole Diameter	Head Width	ETA Seismic Rating	Total Height	Total Width	Total Length
Reference Letter		ls		Drive	d0	HW		H	W	L
Unit description		mm			mm	mm		mm	mm	mm
62512304	4443326	40	6	T30	6	17	C1	17	17	44
62512306	4443327	60	6	T30	6	17	C1	17	17	64