

Walraven W-LX-H Concrete Screw

(L0355)

ultimate performance zinc-plated concrete screws for anchoring in cracked and non-cracked concrete

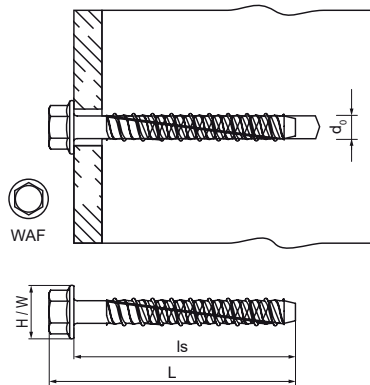

Features & benefits

- very high load capacity
- up to 3 anchoring depths provide maximum installation and design flexibility
- reduced edge and anchor spacing distances
- unique tip and thread geometry prevents concrete spalling
- material: steel
- zinc plated
- fire resistance class R30-R120
- seismic performance categories C1 and C2 (Ø 8/10/14)
- complies with VdS CEA 4001:2014-04 (05) and VdS CEA 4001:2018-01 (06) for applications with sprinkler systems in concrete elements
- substrate type: cracked concrete, non-cracked concrete, precast pre-stressed hollow core slabs
- for loads and more information, refer to the product data sheets and/or the ETA reports



Product Number	RSK Number	Screw Length	Anchor Size	Width Across Flats	Drill Hole Diameter	Total Height	Total Width	Total Length
Reference letter		ls	WAF	d0	H	W	L	
Unit description		mm	mm	mm	mm	mm	mm	
62430304	4444057	40	6	10	6	14	14	47
62430306	4444058	60	6	10	6	14	14	67
62430308	4444059	75	6	10	6	14	14	82
62430406	4444060	60	8	13	8	18	18	68
62430408	4444061	75	8	13	8	18	18	83
62430410	4444063	100	8	13	8	18	18	108
62430412	4444064	120	8	13	8	18	18	128
62430507	4444065	65	10	15	10	22	22	74
62430509	4444066	90	10	15	10	22	22	99
62430510	4444067	100	10	15	10	22	22	109
62430608	4444070	75	12	16	12	27	27	87
62430610	4444071	100	12	16	12	27	27	112
62430713	4444073	135	14	19	14	32	32	148