

## Walraven W-LX-PX Concrete Screw

(L0357)

zinc-plated concrete screw with a  $\varnothing 17.0$  mm pan head and torx T30 drive

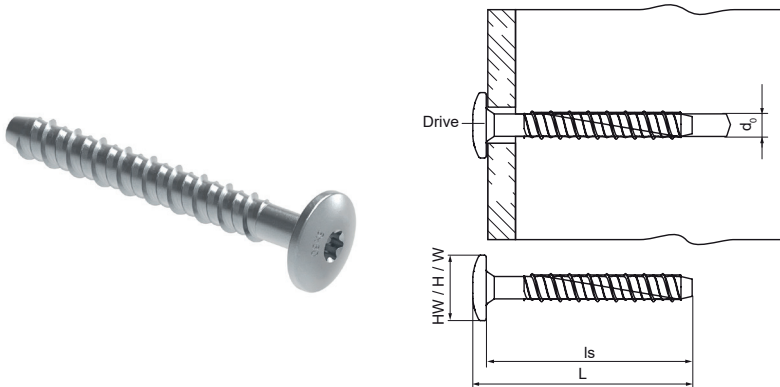

### Features & benefits

- very high load capacity
- approved for use in precast prestressed hollow core slabs
- up to 3 anchoring depths provide maximum installation and design flexibility
- reduced edge and anchor spacing distances
- removable
- unique tip and thread geometry prevents concrete spalling
- material: steel
- zinc plated
- fire resistance class R30-R120 for design of anchorages under exposure to fire
- complies with VdS CEA 4001:2014-04 (05) and VdS CEA 4001:2018-01 (06) for applications with sprinkler systems in concrete elements
- substrate type: cracked concrete, non-cracked concrete, precast pre-stressed hollow core slabs
- for loads and more information, refer to the product data sheets and/or the ETA reports

Product Number	RSK Number	Screw Length	Anchor Size	Key Driver Size	Drill Hole Diameter	Head Width	Total Height	Total Width	Total Length
Reference letter		ls		Drive	d0	HW	H	W	L
Unit description		mm			mm	mm	mm	mm	mm
62432304	4444076	40	6	T30	6	17	17	17	44
62432306	4444077	60	6	T30	6	17	17	17	64