

Walraven Heavy Duty Clamp HD500 (M10/12) (Black)

(B1041)

for steel and stainless steel pipes, including fire mains

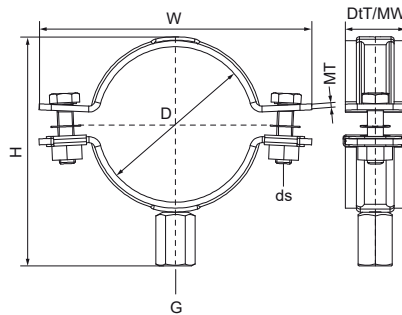

Features & benefits

- two-part clamp with two locking bolts
- up to and including 5": locking nut is captive, hidden in plastic holder
- heavy design
- bolts secured with anti-loss washers
- with 360° CO₂ welded connection nut
- suitable for fire mains (DIN1988-600)
- with M10/12 connection for higher flexibility
- can be used with stainless steel pipe; the epoxy powder coating prevents contact corrosion between clamp and pipe
- material: steel
- surface protection:
 - black (RAL 9005) epoxy powder coating (60 µm)
 - product is part of the Walraven BIS UltraProtect® 1000 system
- suitable for in- and outdoor applications
- stands min. 1,000 hours salt spray test (max. 5% red rust) according to ISO 9227
- tested for fire safet



Product Number	Outside Pipe Diameter	DN	Pipe Diameter Imperial	Connection Thread	Total Height	Total Width	Total Depth	Material Width	Material Thickness	Screw Size	Maximum Allowed Load Faz	Approvals
Reference Letter	D	D	D	G	H	W	DiT	MW	MT	ds	Fa,z	
Unit description	mm		"		mm	mm	mm	mm	mm		N	
3304B078	72 - 78	DN 65	2½	M10/M12	115	137	32	30	3.00	M8	4,000	VdS, ITB (KOT)
3304B092	86 - 92	DN 80	3	M10/M12	129	151	32	30	3.00	M8	4,000	VdS, ITB (KOT), EPD
3304B116	108 - 116	DN 100	4	M10/M12	153	175	32	30	3.00	M8	4,000	VdS, ITB (KOT)