

## Walraven WT1 Throughbolt Anchor SSt

(M9523)

ultimate performance stainless steel expansion anchor for cracked concrete

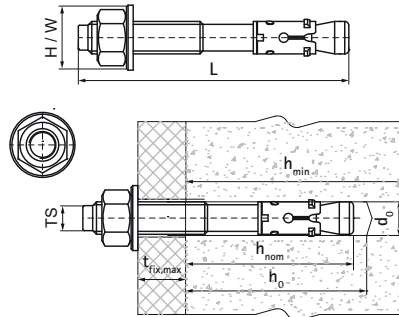

### Features & benefits

- superior load capacity
- ETA Option 1 approval for cracked and non-cracked concrete
- fire resistance class R30-R120 for design of anchorages under exposure to fire
- seismic performance category C1 and C2 for design of anchorages under seismic action
- complies with VdS CEA 4001: 2024-01 (08) for applications with sprinkler systems in concrete elements
- substrate type: cracked concrete, non-cracked concrete, stone
- pre- and through-fixing
- made of stainless steel for use in external atmospheric environment
- material: stainless steel A4
- for loads and more information, refer to the product data sheet and/or the ETA reports

Product Number	Thread Size	Total Length	Drill Hole Diameter	Drill Hole Depth	Minimum Substrate Thickness	Maximum Fixture Thickness	Standard Embedment Depth	ETA Seismic Rating	Recommended Load In Cracked Concrete C20/25	Recommended Load In Uncracked Concrete C20/25	Total Height	Total Width
Reference Letter	TS	L	d0	h0	hmin	tfix,max	hnom		N	N	H	W
Unit description		mm	mm	mm	mm	mm	mm				mm	mm
608608075	M8	75	8	60	100	9	55		4,000	5,700	16	16
608610090	M10	90	10	75	120	10	68	C1 & C2	6,600	7,600	20	20
608610135	M10	135	10	75	120	55	68	C1 & C2	6,600	7,600	20	20
608612120	M12	120	12	85	140	24	80	C1 & C2	7,500	8,700	24	24
608612150	M12	150	12	85	140	54	80	C1 & C2	7,500	8,700	24	24