

# WGB-M Aerated Concrete Anchor

## Metal anchor for applications in autoclaved aerated concrete

### Anchor types



**Anchor**  
WGB-M M10  
WGB-M M12

**Setting Tool**  
WGB-M ST

- **WGB-M** is a deformation-controlled metal anchor for autoclaved aerated concrete with DIBt technical approval and VdS certificate for installation of stationary fire extinguishing systems. It is made of galvanized steel and the installation does not require drilling. WGB-M has a fire resistance class R90-R120.

### Features and benefits

- internal thread connection allows flexible distance from the anchor to the fixture
- load can be applied immediately after the installation
- four-way expansion provides high permissible loads, even in tensile areas of roofs and ceilings
- VdS certificate for applications in stationary water extinguishing systems for dry inner rooms
- high load safety due to undercutting expansion
- designed specifically for use aerated concrete
- very high load capacity
- installation does not require drilling
- fire resistance class R90-R120 for design of anchorages under exposure to fire
- easy installation

### Suitable base materials



Aerated concrete blocks and elements

### Approvals and certificates

- DIBt Technical Approval
- Fire Performance
- VdS Certificate

Z-21.1-1525, 2 June 2021  
Z-21.1-1525, 2 June 2021  
G 4980083, 10 October 2022



## 1. Product details

Article	Description	Cone bolt			Expansion sleeve		Connection sleeve		
		Cone dia.	Cone length	length	length	thread	length	thread	dia.
		$d_1$ [mm]	$l_d$ [mm]	$l_b$ [mm]	$l_c$ [mm]	$d_g$ [mm]	$l_k$ [mm]	$d_i$ [mm]	$d_h$ [mm]
6103510	WGB-M	14	12	55	45	M10	35	M10	16
6103512	WGB-M	14	12	55	45	M10	35	M12	16

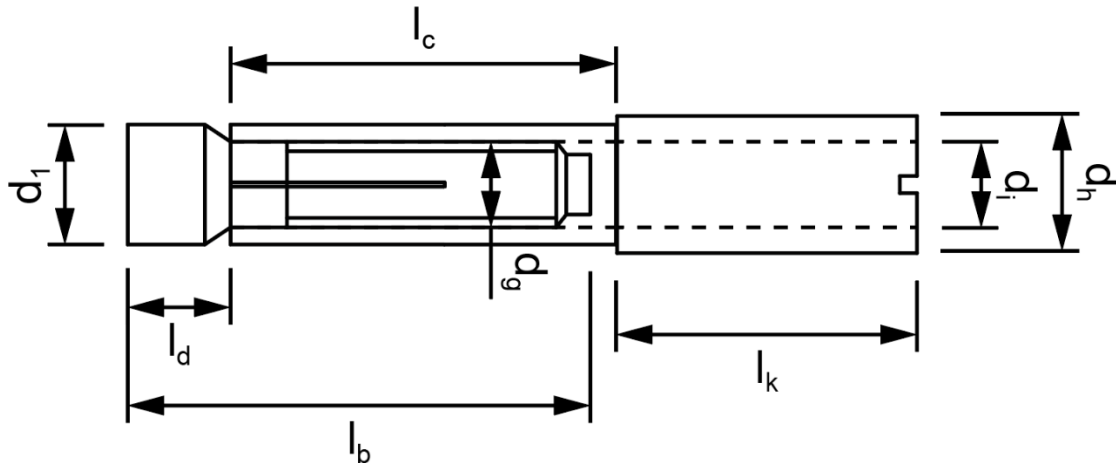

## 2. Setting tool details

Article	Description	Size	For WGB-M
6103510	WGB-M ST	M10/M12	WGB-M M10 WGB-M M12

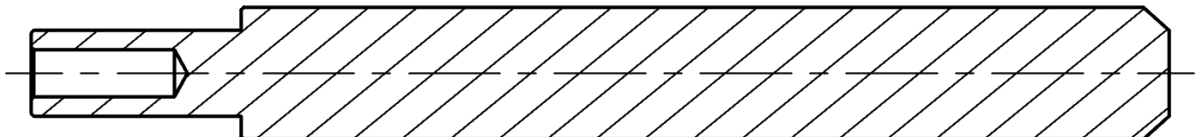

## 3. Packaging details

Article	Description	Pack 1	
		[pcs]	EAN13
6103510	WGB-M M10	50	8719942032162
6103512	WGB-M M12	50	8719942032193
6902511	WGB-M ST	1	8719942025119

## 4. Mechanical properties

Property	WGB-M
Expansion pin	St. 1.0718/1.0737, DIN EN 10277-3
Expansion sleeve	St. 1.0718/1.0737, DIN EN 10277-3
Threaded sleeve	St. 1.0718/1.0737, DIN EN 10277-3

## 5. Installation parameters and intended use

### 5.1 Specification of intended use

- Predominantly static loads
- The anchoring base material must be made of unplastered or uncoated masonry walls made of autoclaved aerated concrete blocks or flat elements of at least strength class 2 in accordance to DIN 4165 or generally approved building panels, reinforced or unreinforced wall panels as well as roof and ceiling panels made of steam-hardened aerated autoclaved concrete of at least strength class 3.3.
- The mortar must meet strength properties of mortar group II or higher according to DIN 1053-1: 1 1996-1, Appendix A.
- For anchoring in light ceiling panels and false ceilings in accordance with DIN EN 13964: 2007-02
- For use in dry inner rooms

### 5.2 Installation parameters

Anchor Type			WGB-M	
Anchor Size			M10	M12
Setting depth, expansion pin	$h_{ef}$	[mm]	67	67
Diameter of clearing hole in the fixture	$d_f$	[mm]	12	14
Installation torque	$T_{inst}$	[Nm]	8	8
Min. fastening screw engagement distance	$l_{s,min}$	[mm]	10	12
Max. fastening screw engagement distance	$l_{s,max}$	[mm]	18	18
Allowed bending moment for fastening screw	$M$	[Nm]	21.4	37.4
Min. fastening screw property class according to DIN 898-1			class $\geq 5.8$	

### 5.3 Aerated autoclaved concrete blocks and flat elements according to DIN 4165

Strength Class	Compressive Strength		Density class	Average density <sup>1)</sup> [kg/dm <sup>3</sup> ]
	Average [N/mm <sup>2</sup> ] min	Minimum [N/mm <sup>2</sup> ]		
2	2.5	2.0	0.35	$\geq 0.30 - 0.35$
			0.40	$\geq 0.35 - 0.40$
			0.45	$\geq 0.40 - 0.45$
			0.50	$\geq 0.45 - 0.50$
4	5.0	4.0	0.55	$\geq 0.50 - 0.55$
			0.60	$\geq 0.55 - 0.60$
			0.65	$\geq 0.60 - 0.65$
			0.70	$\geq 0.65 - 0.70$
6	7.5	6.0	0.80	$\geq 0.70 - 0.80$
			0.65	$\geq 0.60 - 0.65$
			0.70	$\geq 0.65 - 0.70$
8	10.0	8.0	0.80	$\geq 0.70 - 0.80$
			0.90	$\geq 0.80 - 0.90$
			1.00	$\geq 0.90 - 1.00$

### 5.4 Anchor spacing and member dimensions

Anchor Type		WGB-M
Minimum edge distance to edge of the member and to vertical joints	$a_r \geq$ [cm]	15
Minimum distance to horizontal joints	$a_{rL} \geq$ [cm]	5
Minimum spacing	$a_z \geq$ [cm]	60
Spacing between anchor pairs <sup>1)</sup>	$a \geq$ [cm]	10
	$a \geq$ [cm]	20
Minimum thickness of member	$d$ [cm]	17.5

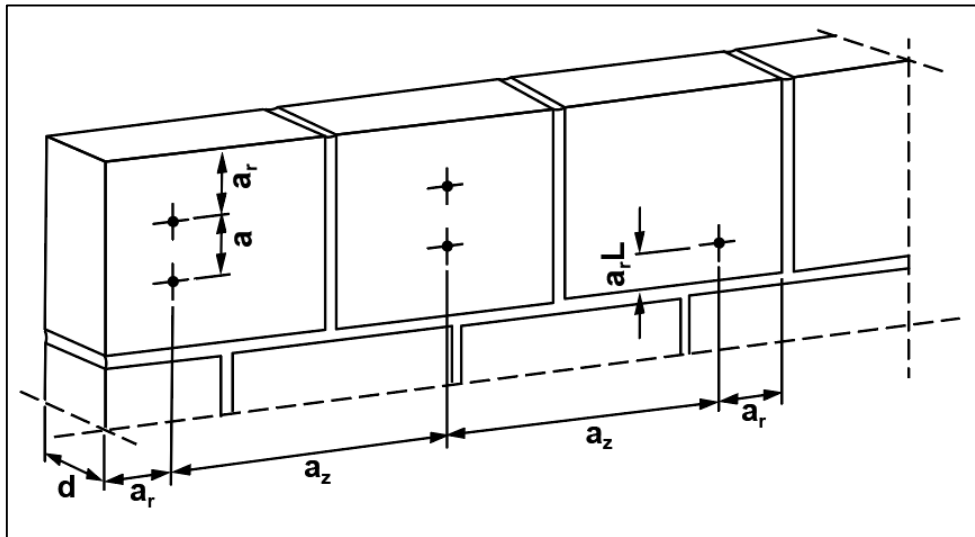

Figure 1 Uncracked autoclaved aerated concrete, see paragraph 6.1

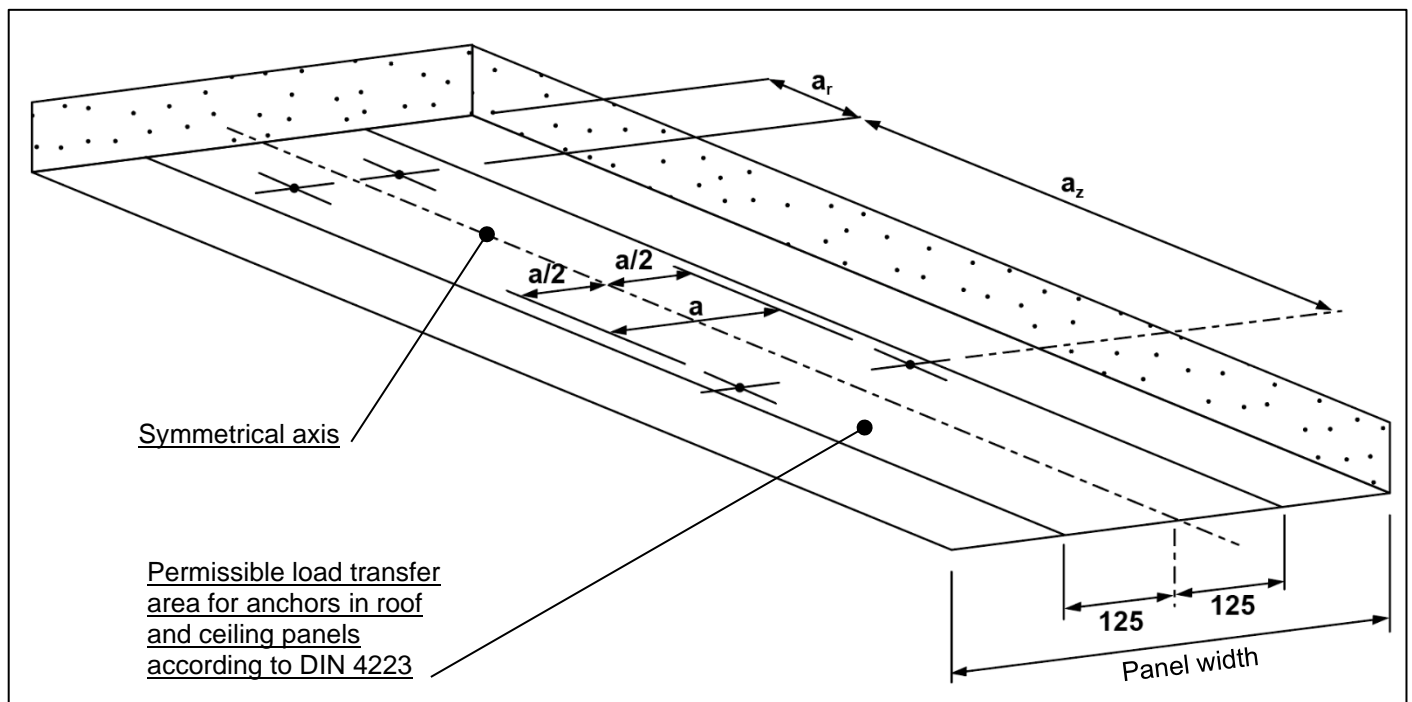
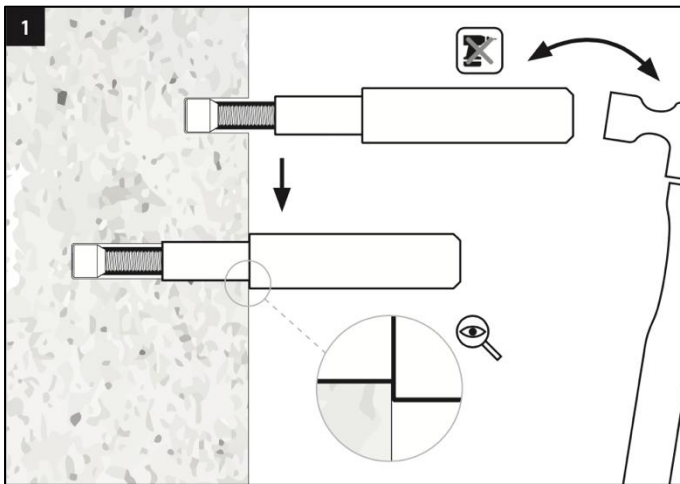
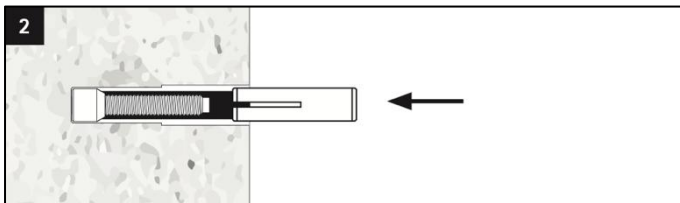

Figure 2 Cracked autoclaved aerated concrete, see paragraph 6.2

## 5.5 Installation procedure



Hammer the cone bolt into the aerated concrete using WGB-M ST setting tool



Slide the expansion sleeve onto the expansion pin

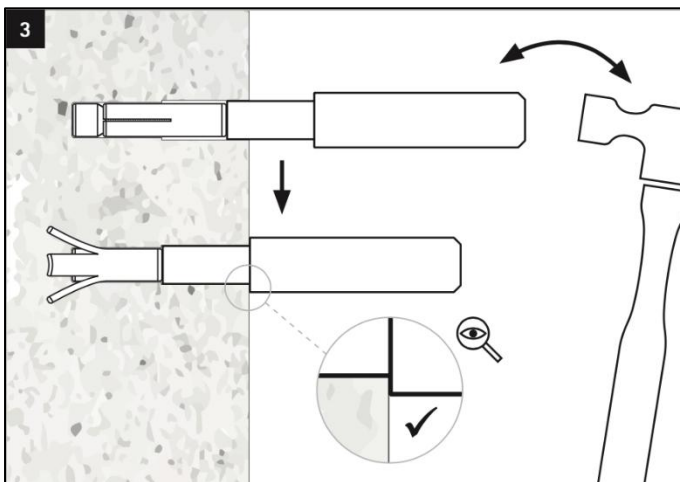

Position the WGB-M ST setting tool over the expansion sleeve and hammer the sleeve until the stop rim of the setting tool meets the surface of the aerated concrete

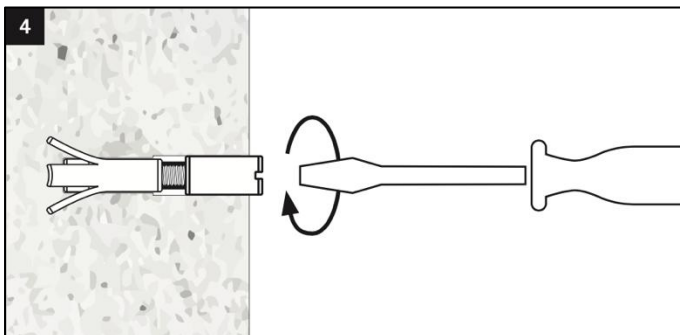

Screw the connection sleeve onto the cone bolt

## 5.5 Installation procedure, continued

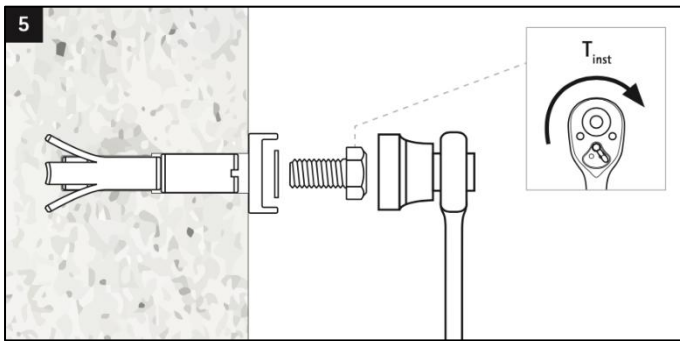

Tighten the screw with torque wrench and apply 8 Nm of torque. The anchor may be loaded only if the prescribed torque can be applied.

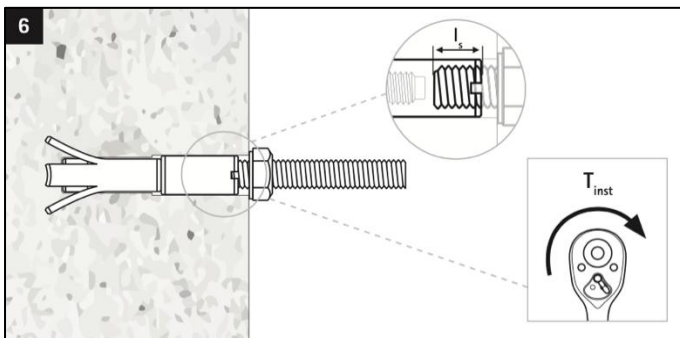

If mounting threaded rods, it is essential to achieve thread engagement as specified in paragraph 5.2. Tip: if the threaded rod was screwed in completely, turn it back by 2 full turns to achieve correct engagement depth.

## 6. Performance information

### 6.1 Recommended tension, shear and combined tension and shear (at any angle) loads in uncracked aerated concrete <sup>1) 2)</sup>

Anchor Type			WGB-M	
			M10	M12
<b>Anchor Size</b>				
<b>Single WGB-M Anchor</b>				
Recommended load, AAC 2	F <sub>Rec</sub>	[kN]	0.6	0.6
Recommended load, AAC ≥4	F <sub>Rec</sub>	[kN]	1.2	1.2
Recommended load, wall panel, GB 3.3	F <sub>Rec</sub>	[kN]	0.8	0.8
Recommended load, wall panel, GB 4.4	F <sub>Rec</sub>	[kN]	1.2	1.2
<b>Pair of WGB-M Anchors, centre distance between anchors a ≥ 10mm</b>				
Recommended load, AAC 2	F <sub>Rec</sub>	[kN]	0.6	0.6
Recommended load, AAC ≥4	F <sub>Rec</sub>	[kN]	1.2	1.2
Recommended load, wall panel, AAC GB 3.3	F <sub>Rec</sub>	[kN]	0.8	0.8
Recommended load, wall panel, AAC GB 4.4	F <sub>Rec</sub>	[kN]	1.2	1.2
<b>Pair of WGB-M Anchors, centre distance between anchors a ≥ 20mm</b>				
Recommended load, AAC 2	F <sub>Rec</sub>	[kN]	0.8	0.8
Recommended load, AAC ≥4	F <sub>Rec</sub>	[kN]	1.7	1.7
Recommended load, wall panel, AAC GB 3.3	F <sub>Rec</sub>	[kN]	1.1	1.1
Recommended load, wall panel, AAC GB 4.4	F <sub>Rec</sub>	[kN]	1.7	1.7

1) The fixing of the anchors is only permissible in unplastered and uncoated masonry walls.

2) For masonry made of small-format aerated concrete blocks and lightweight masonry mortar, the permitted tension load (perm. F) for single anchors and anchor pairs must be reduced by a factor of 0.6.

### 6.2 Recommended tension, shear and combined tension and shear (at any angle) loads in cracked aerated concrete <sup>1)</sup>

Anchor Type			WGB-M	
			M10	M12
<b>Anchor Size</b>				
<b>Single WGB-M Anchor</b>				
Recommended load, wall panel, GB 3.3	F <sub>Rec</sub>	[kN]	0.8	0.8
Recommended load, wall panel, GB 4.4	F <sub>Rec</sub>	[kN]	1.2	1.2
<b>Pair of WGB-M Anchors, centre distance between anchors a ≥ 10mm</b>				
Recommended load, wall panel, GB 3.3	F <sub>Rec</sub>	[kN]	0.8	0.8
Recommended load, wall panel, GB 4.4	F <sub>Rec</sub>	[kN]	1.2	1.2
<b>Pair of WGB-M Anchors, centre distance between anchors a ≥ 20mm</b>				
Recommended load, wall panel, GB 3.3	F <sub>Rec</sub>	[kN]	1.1	1.1
Recommended load, wall panel, GB 4.4	F <sub>Rec</sub>	[kN]	1.7	1.7

1) The shear stress determined by the anchor load must not exceed the value  $0.4 \times \text{perm. } \tau$  according to DIN 4223, see section 3.2.6.

**6.3 Recommended load  $F_{Rec}$  for anchoring light ceiling linings and false ceilings according to DIN 18168, ventilation ducts and comparable components under fire exposure.**

Anchor Type			WGB-M			
Anchor Size			M10		M12	
Fire rating	[min]		90	120	90	120
Recommended load in AAC strength class $\geq$ P3,3	$F_{Rec}$	[kN]	0.80	0.75	0.80	0.75

**6.4 Recommended load  $F_{Rec}$  for anchoring facade claddings, if a load transfer to at least one adjacent fixing point is possible.**

Anchor Type			WGB-M			
Anchor Size			M10		M12	
Fire rating	[min]		90	120	90	120
Recommended load in AAC strength class $\geq$ PB2, PP2 and $\geq$ P3,3	$F_{Rec}$	[kN]	0.80	0.75	0.80	0.75